

Application and verification of ECMWF products 2017

METEO-FRANCE J. Stein, L. Aouf, G. Faure, N. Girardot, S. Guidotti, O. Mestre, D. Paradis, M. Plu and I. Sanchez

1. Summary of major highlights

ECMWF deterministic and ensemble forecasts have continued to be an important component of Meteo-France production, both as an input for the forecasters decision-making, as a digital products for the end users (usually after a calibration process that if more and more involving a probabilistic component and ensembles), and as a forcing for atmospheric and sea surface (waves and surges) models. Some of these products are made available as part of the COPERNICUS services (CAMS and CMEMS)

The major highlights for 2016/ 2017 have been:

1. the operational implementation of Arome over 5 domains overseas (2.5km resolution, initial conditions and hourly forcing provided by ECMWF BC project, see para 2.1.2 “Limited models”)
2. the provision of global wave forecasts driven by ECMWF winds and ice fraction data to the Copernicus Marine Environment Monitoring Services (CMEMS, see para 2.1.2 “Wave models”)
3. the contribution to the COPERNICUS atmospheric monitoring services (CAMS) through the provision of MOCAGE data has been upgraded: analyses are now provided based on ECMWF 00UTC forecasts instead of 12UTC forecasts from the day before.
4. the kick-off given to the redesign project of Météo-France forecasts and product generation chain (3P); ECMWF deterministic and ensemble forecasts will be an important component of this multi-model, multi ensembles system; a first example of direct model output post-processing is provided in para 2.1.3

2. Use and application of products

2.1 Post-processing of ECMWF model output

2.1.1 Statistical adaptation

Millions of local forecasts of weather parameters are produced daily through statistical adaptation of NWP output. Main methods are multiple linear regression (MLR) and linear discriminant analysis (DA). MOS (model output statistics) is generally preferred to PP (perfect prognosis). Kalman filter (KF) is applied when relevant. The production is described in Table 1.

Note the new production of grid point total cloud cover forecast based on a statistical adaptation using satellite data as predictand.

Deterministic model

Parameter	Method	Domain	Nbr of Sites	Steps
Tri-hourly 2m Temperature	MLR (MOS) +KF	France	2781	+3h to +180h by 3h
Daily extremes 2m temperature	MLR (MOS) +KF	France	2781	D to D+6
10m Wind Speed	MLR (MOS)	France	861	+6h to +180h by 3h
10m Wind Direction	MLR (MOS)	France	822	+6h to +180h by 3h
Total Cloud Cover	MLR (MOS)/LDA	France	164/152	+12h to +180h by 3h
Total Cloud Cover	LDA	France	GRID 0.5x0.5	0h to +156h by 3h
Tri-hourly 2m relative Humidity	MLR (MOS) +KF	France	1269	+6h to +180h by 3h
Daily extremes 2m rel. Humidity	MLR (MOS) +KF	France	1269	D to D+6
Tri-hourly 2m Temperature	MLR (MOS) +KF	World	7128	+1h to +180h by 1h
Daily extremes 2m temperature	MLR (MOS) +KF	World	7128	D to D+6

Mixed ARPEGE+IFS	MLR (MOS) +KF	France	2781	+3h to +102h by 3h
Mixed ARPEGE+IFS	MLR (MOS) +KF	World	4367	+1h to +102h by 1h

Table 1 : Statistical adaptations for the deterministic high resolution model

Ensemble (EPS)

* EPS Ensemble mean and individual members

Statistical post-processing is applied to individual ensemble members (Table 2). Methods are the same as for the deterministic model output but pseudo-PP (statistical equations computed during the first 24 hours then applied to the other corresponding steps) is preferred to MOS. VAREPS is used and Météo-France provides local forecast (temperatures) up to 14 days.

Parameter	Method	Domain	Nbr of Sites	Steps
Tri-hourly 2m Temperature	MLR (pPP) +KF	France	2761	+3h to +360h by 3h
Daily extremes 2m temperature	MLR (pPP) +KF	France	2761	D to D+14
10m Wind Speed	MLR	France	792	+6h to +240h by 3h +246 to +360 by 6h
Tri-hourly 2m relative Humidity	MLR (pPP) +KF	France	1146	0h to +240h by 3h
Daily extremes 2m rel. Humidity	MLR (pPP) +KF	France	1146	D to D+10
Tri-hourly 2m Temperature	MLR (pPP) +KF	World	3338	+0h to +360h by 3h (by 1h for ensemble mean)
Daily extremes 2m temperature	MLR (pPP) +KF	World	3338	D to D+14

Table 2 : Statistical adaptations for the EPS

* EPS Distribution

Calibration is applied to the EPS distribution in order to improve the reliability. Operationally, a calibration based on rank diagrams is used for 10m wind speed and total precipitations. The post-processing and calibration of ensembles has become an important component of Meteo-France research and development (e.g. Zamo, 2016), and will become an important part of the forecast and production re-engineering project (3P)

Monthly forecast

Statistical post-processing is also applied to the monthly forecasts up to 32 days (Table 3). These locally corrected forecasts are used as inputs in electricity consumption models.

Parameter	Method	Domain	Nbr of Sites	Steps
Tri-hourly 2m Temperature	MLR (pPP)	France	1056	+0h to +768h by 3h
Daily extremes 2m temperature	MLR (pPP)	France	1056	D to D+31
Tri-hourly 2m Temperature	MLR (pPP)	World	7128	+0h to +768h by 3h
Daily extremes 2m temperature	MLR (pPP)	World	7128	D to D+31

Table 3 : Statistical adaptations for the monthly forecasts

2.1.2 Physical adaptation

Limited –area models

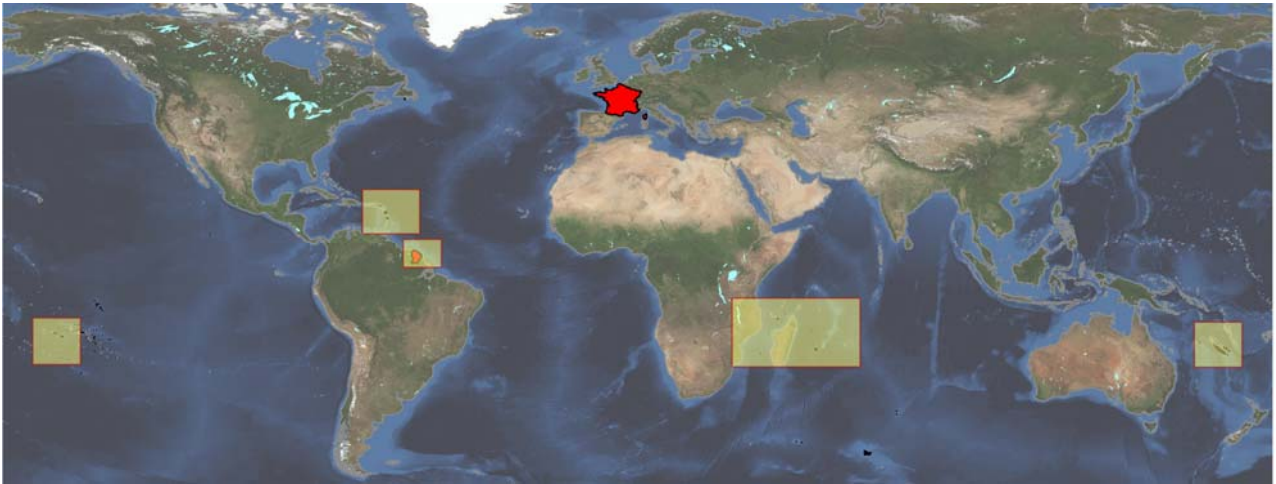

Fig. 1: Five Limited Area Model, based on AROME, are operated by Météo-France to provide high-resolution forecasts for tropical area including French overseas territories (Figure 1). Their horizontal resolution is equal to 2.5 km. HRES provides their initial and boundary conditions. Four daily runs are performed at 0, 6, 12 and 18 UTC, with a maximum lead time of 42 hours. The surface conditions are provided by the French global model ARPEGE.

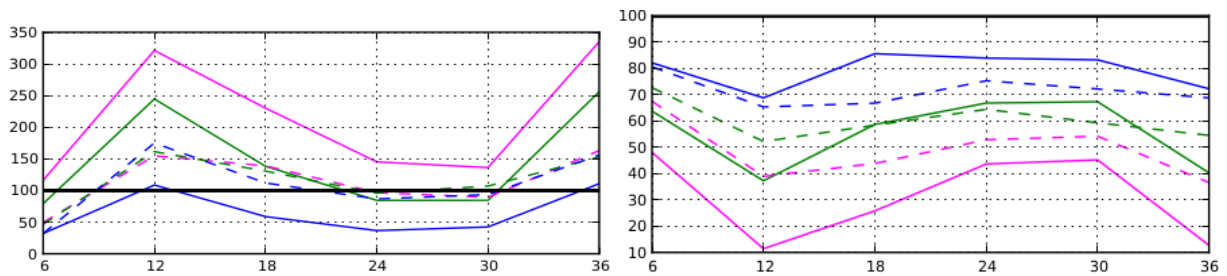

Fig. 2: Frequency bias (left) and miss ratio (right) for three thresholds 0.2mm/6h (pink) 2mm/6h (green) and 10mm/6h (blue) 6 hours precipitation forecasts performed by the AROME-ECMWF (dashed lines) and IFS (full lines). The scores are computed against the French rain gauge network operated in La Réunion (Indian Ocean) for the year 2016 and are displayed for each six hours forecast lead time.

AROME-ECMWF underestimates the accumulated rain during the 6 first hours of forecast. Because of the local adaptation of the IFS analysis to the AROME-ECMWF topography and the difference between the physical packages, AROME-ECMWF lowers the number of forecasted rains and so false alarms (not shown) but this underestimation increases the AROME-ECMWF's misses.

For longer lead times and for light rains, 0.2mm/6h thresholds, both models present a diurnal cycle of bias with overestimation at 12UTC and better frequency biases during the night. AROME-ECMWF has better biases than IFS, this reduction of overestimations leads to less false alarms (not shown) but increases misses. Moderate rains, 2mm/6h threshold, shows similar behaviour on bias and misses : reduction of IFS overestimations and increasing misses.

Heavy rains, 10mm/6h, are underestimated by IFS and corrected by AROME-ECMWF. This difference produces more false alarms for AROME-ECMWF than IFS (not shown) but a benefit in detection even if they remain rather low.

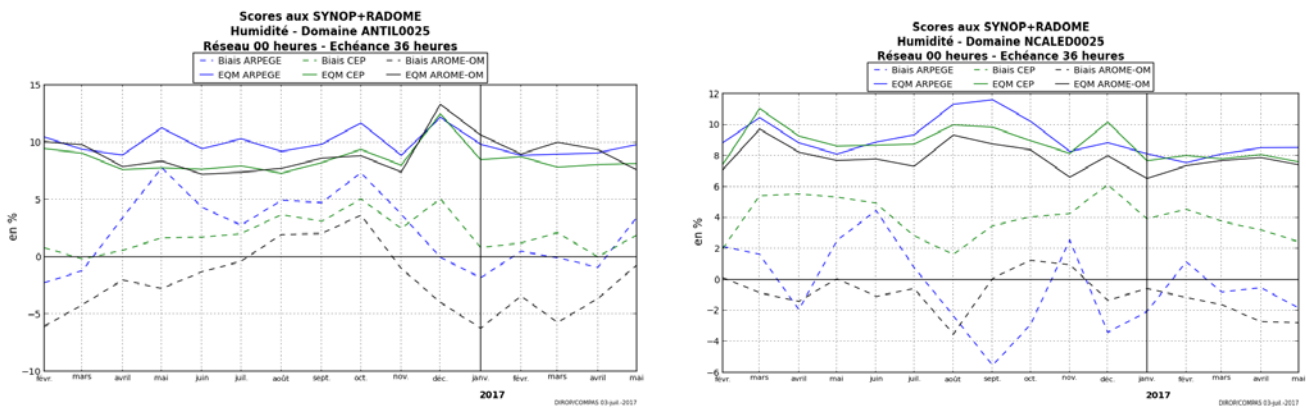

Fig. 3: Temporal series of the RMSE (full lines) and bias (dotted lines) for relative humidity at 2m AGL forecasted at 36 hours of lead time by AROME Antilles (black lines) ARPEGE (blue lines) and IFS (green lines) on the left panel. The reference is provided by the surface stations included in the LAM domain and the errors are monthly averages. The same comparison is presented for the AROME-Nouvelle Calédonie on the right panel at 36 hours.

The temporal series of the RMSE for the relative humidity at 2m AGL present a reduction of bias over both areas by AROME, leading most of the time to under-estimation. Slight differences in RMSE between AROME-ECMWF and IFS occur over the Antilles domain. Over the NOUVELLE CALEDONIE area, AROME-ECMWF has better behaviours than IFS: better biases and RMSE during the 2016 year.

Wave models

Since last April 2017, the operational wave model MFWAM driven by the deterministic ECMWF-IFS winds and ice fraction fields is providing wave products to the global Copernicus Monitoring and Forecasting Centre (CMEMS-MFC-GLO). The model MFWAM of Météo-France is based on the ECWAM code (IFS-38R2), but uses a different physical package including the dissipation by wave breaking and the damping of the swell induced by the air-friction at the sea surface. A global version and a regional (European coasts) versions centered on Europe have a horizontal grid meshes of 0.2° and 0.1°, respectively. Both global and regional models MFWAM assimilate the altimeters wave data (Jason-2, Saral/Altika, Cryosat-2 and Jason-3 since October 2016).

The global model MFWAM is among the best wave forecasting system regarding to monthly intercomparison of JCOMM, as illustrated in Fig. 4, which shows the variation of normalized scatter index of significant wave height in the analysis and forecast periods during April 2017. The performance of the global MFWAM system regarding to altimeters wave data shows a good scatter index of significant wave height in average of 10% during the 12-hour forecast, as illustrated in Fig.5. The highest and lowest scatter indexes are located in coastal areas and in the intermediate latitudes and the tropics, respectively.

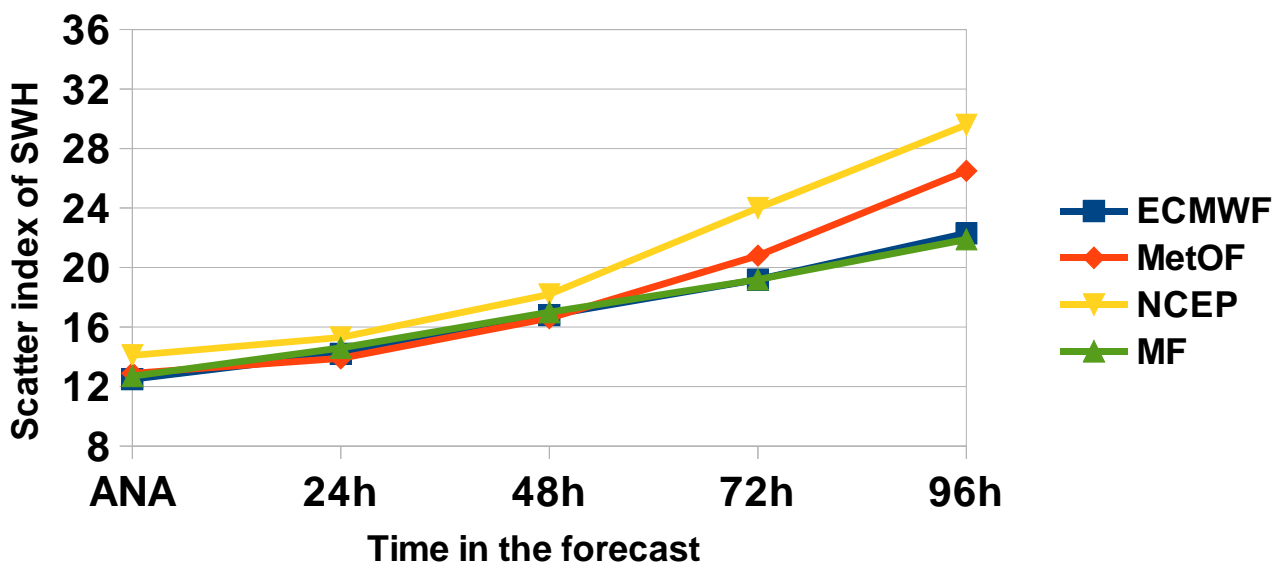

Fig. 4: Monthly Scatter index of significant wave height from the JCOMM intercomparison with buoys on April 2017. Green, blue, red and yellow colors stand for Meteo-France, ECMWF, UK Met-Office and NOAA/NCEP systems, respectively. The smaller scatter index, the better wave forecast is.

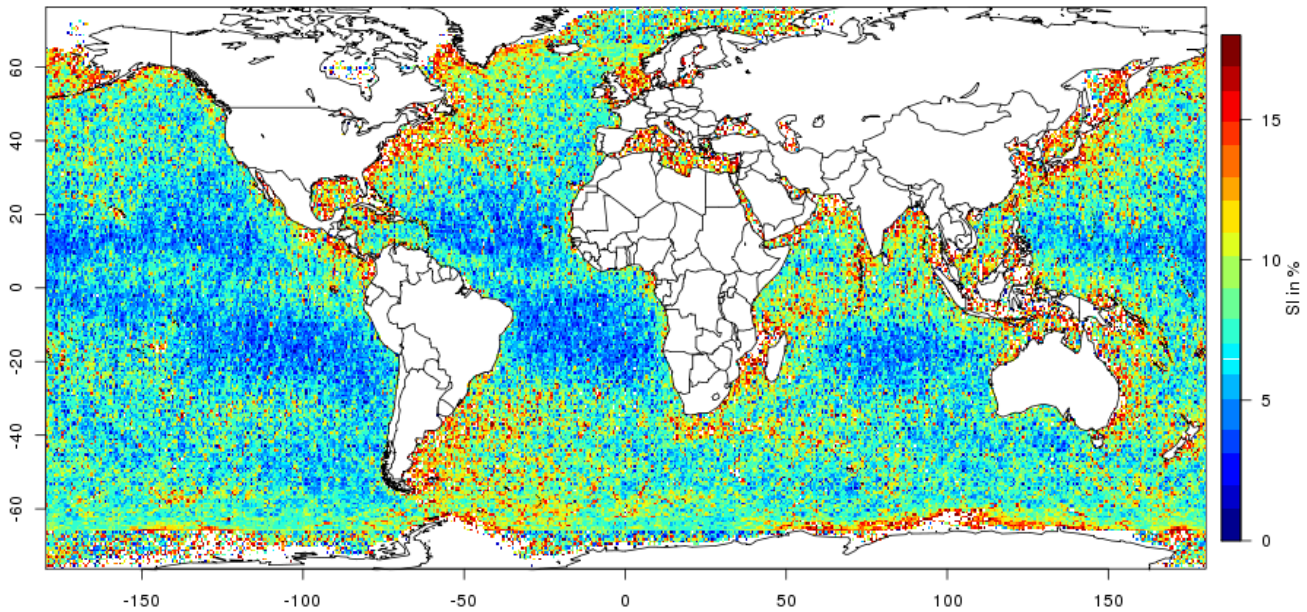

Fig. 5: Map of normalized scatter index of significant wave height during the 12-hour forecast of the global MFWAM system driven by ECMWF forcing for the period of December 2016-March 2017. The comparison is performed with 3-hourly window altimeters wave data during the 12-hour forecast.

Storm surge model

The Météo-France storm surge model is operated 13 times per day in order to use a variety of atmospheric forcings and to allow the forecasters to know the impact of each forcing on the sea level (west european coasts). Thus, the medium range deterministic forecasts of ECMWF are used as forcing, beside the Arpege and the Arome models of Météo-France.

The Météo-France storm surge model, used since the 14th January 2014, has been developed by SHOM and Météo-France in the framework of the HOMONIM project (Historique, Observation, MOdélisation des NiveauxMarins). It is based on a barotropic version of the HYCOM code (<https://hycom.org/>). Two domains, ATL (BiscayeBaye, Channel and North Sea) and MED (Méditerrananean Sea) have been implemented, with a resolution of around 600 m for ATL and 1000 m for MED (curvilinear grids). The bottom friction has been optimized to reproduce the tides at the best. A validation has been done on 22 storm events and on a one year simulation, to calibrate the drag coefficient. Up to date bathymetries have been used.

The one yearsimulationpresents a mean bias of -2 cm. The negative bias is stronger when only high storm surges are taken into account : -5 cm.

For the 22 events, the mean error on the max storm surge peak is around -10 cm (-8 cm on the maximum of the sea level) and the mean time error is 34 minutes.

The operational suite include 4 forecastsa day for this model usingArpege forcing (at 0, 6, 12 and 18 UTC with forecasts until 102, 72, 114 and 60 h respectively), 5 forecasts with AROME forcing (at 0, 3, 6, 12 and 18 UTC with forecasts until 42, 39, 30, 36 and 42 h respectively), and 4 simulations with IFS/HRES forcing (at 0, 6, 12 and 18 UTC with forecasts until 120, 90, 120 and 90 h respectively).

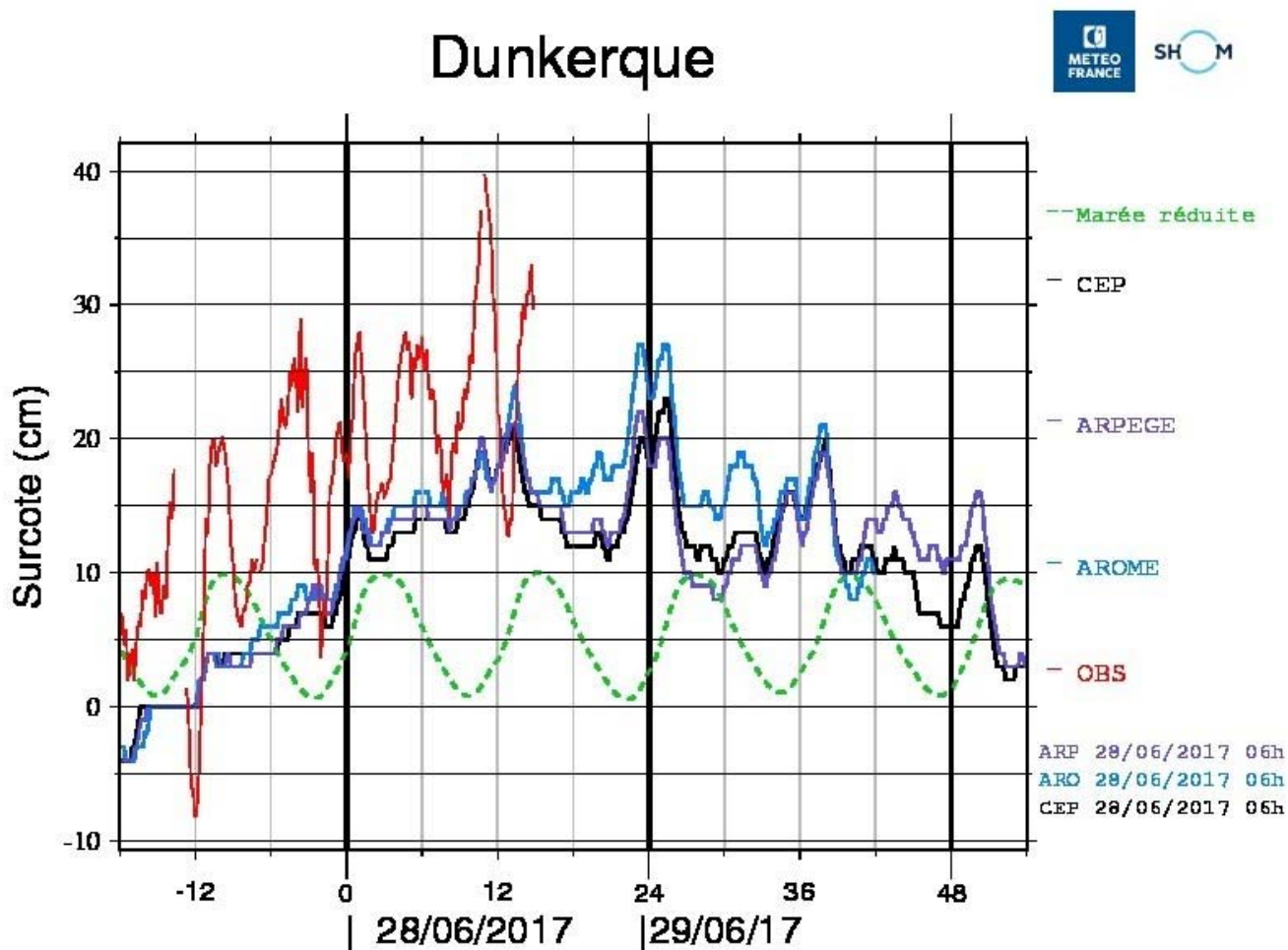

Fig. 6: Temporal series (every 10 minutes) for the storm surge (and the total sea level) forecasted at Dunkerque (North of France) starting the 28/08/2017 at 6 UTC. They are forecasted by the MFWAM model using the forcing provided by the global model IFS (black), the French global model ARPEGE (purple) and the LAM AROME (blue). The red line represents the observations (tide gauges).

The storm surge (and the total sea level) forecasts are mainly visualized as temporal series (every 10 minutes) on specific points of the coast. Fig 6. displays the forecasts at Dunkerque (North of the France) starting the 28th June 2017 at 6 UTC : the black line represents the storm surge computed with the IFS forcing and the red line the observations (tide gauges).

2.1.3 Derived fields

As part of the re-engineering of Météo-France product suite, a new algorithm has been developed to generate weather pictograms on a global scale using ECMWF deterministic forecasts (Fig. 7)

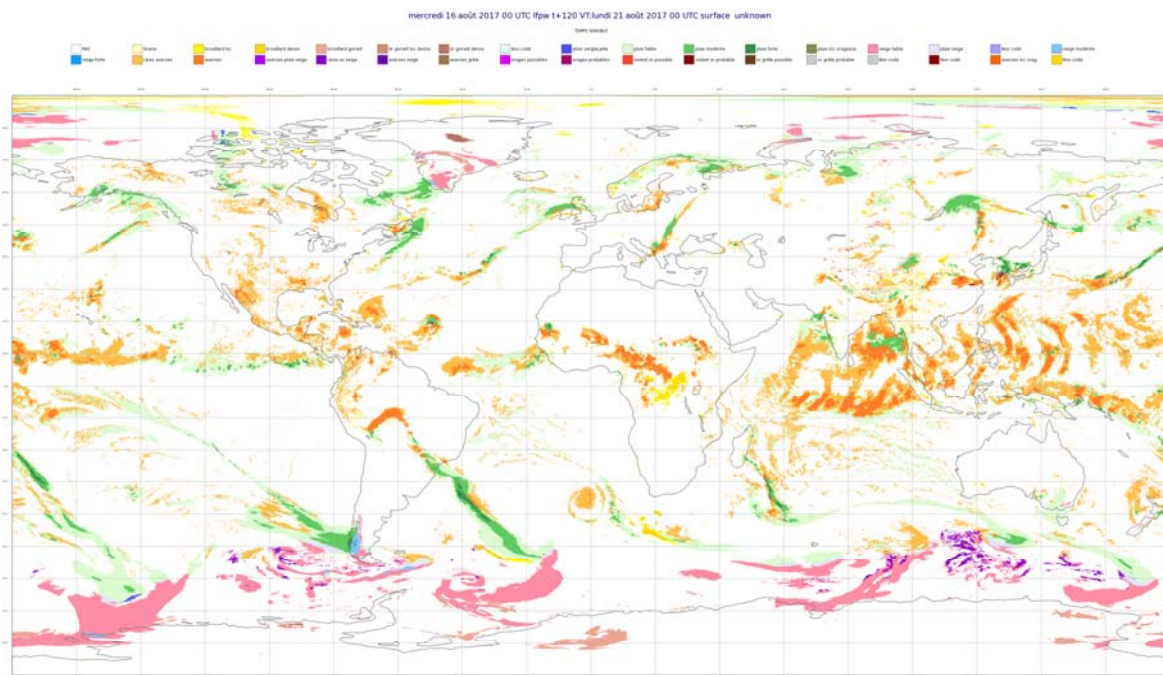

Fig. 7: Example of weather parameters used for pictogram generation over the globe using ECMWF forecasts.

2.2 ECMWF products

2.2.1 Use of Products

2.2.2 Product requests

3. Verification of products

3.1 Objective verification

3.1.1 Direct ECMWF model output (both HRES and ENS)

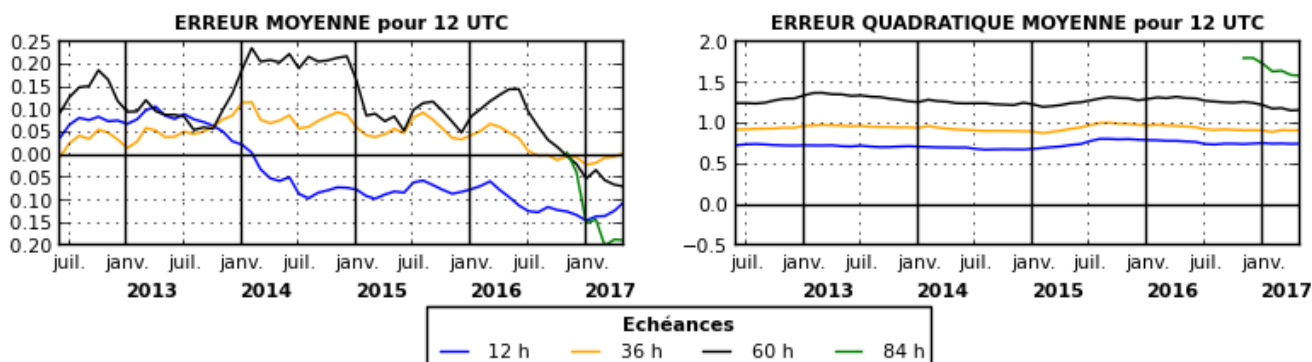

Fig. 8: Temporal series of the RMSE on the right panel and additive bias on the left panel for the Mean Sea Level (MSL) pressure forecasted at 12, 36, 60 and 84 hours by IFS. The reference is provided by the surface stations over France and the errors are averaged during 12 months.

Recent upgrades in ECMWF high resolution forecasts (March and November 2016) led to a reduction of MSL pressure errors over France : 12 hours forecasts still under-estimate MSL pressure while 36 hours forecasts have correct biases. However, for longer lead times IFS underestimates MSL pressure over France, as 84h verifications started at the end of the year 2016. RMSE errors for each lead time had improved since March 2016 and range from 0,75hPa at 12h range to 1,6hPa at 84h range.

3.1.2 ECMWF model output compared to other NWP models

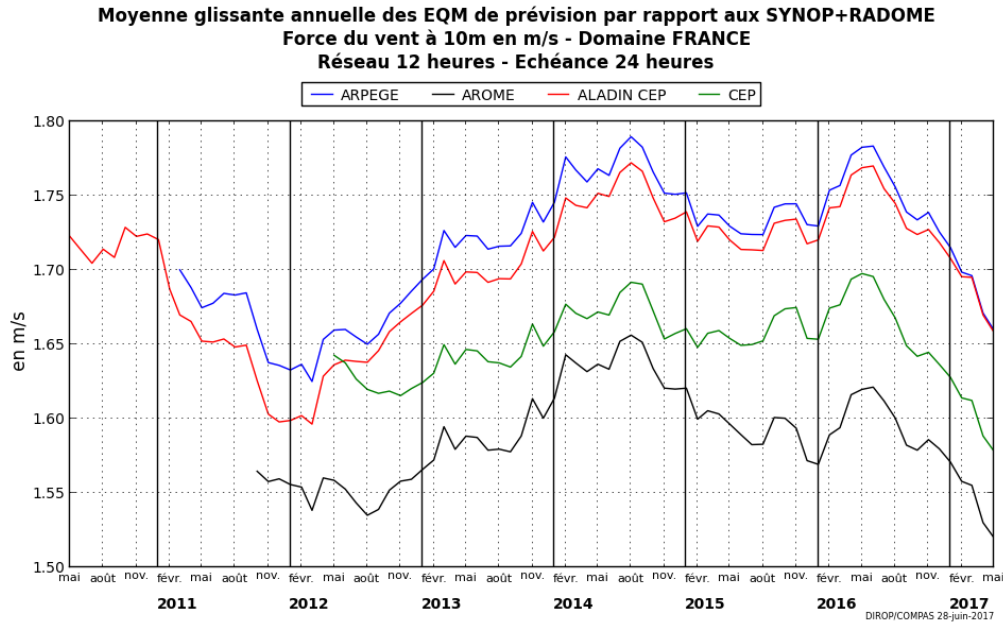

Fig. 9: Verification of the 10m wind force forecasted by IFS (green line) ARPEGE (blue line) ALADIN-CEP (red line) and AROME (black line) for 24 hour forecasts of 12hUTC based time. The reference is provided by the surface stations over France and the Root Mean Squared Errors are 12 months averaged.

The errors of 24h forecasts valid on day 2 at 12hUTC present an annual cycle. Moreover, all models show deteriorations from year 2012 to year 2014, stability during 2015 and improvements since 2016 spring. It proves that this parameter is very sensitive to the climatology of the period. However, AROME better estimates 10m wind force, thanks to its high resolution grid. IFS is in the second position with 1,62m/s RMSE at the end of year 2016. The limited area model ALADIN-CEP, using IFS boundary conditions, shows performance equivalent to ARPEGE for 10m wind force in the early 2017.

3.1.3 Post-processed products

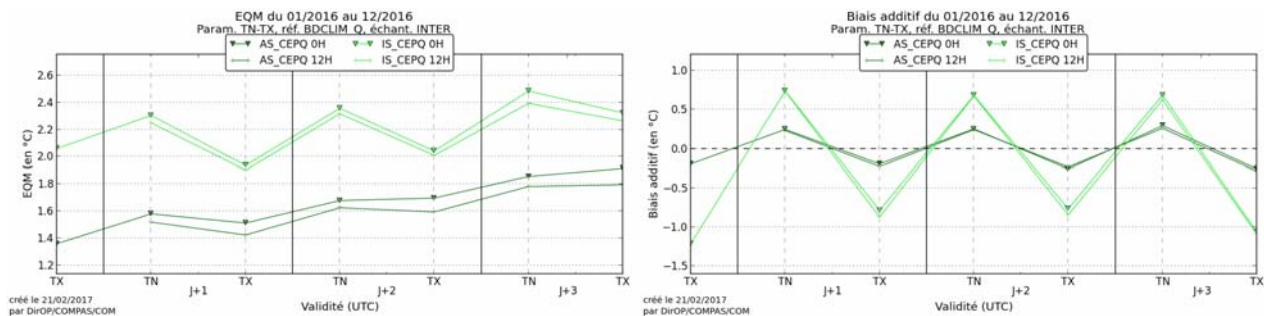

Fig. 10: Verification of the 2m extremal temperatures forecasted by IFS (light green) and calibrated (dark green) : RMSE (on the left panel) and biais (on the right panel) are plotted for both 0 (triangle) and 12UTC (solid line) based time. The reference is provided by the climatological station over France for year 2016.

Temperature forecasts present a diurnal cycle with an overestimation of minimum temperatures and an underestimation of maximum temperatures. Calibration strongly reduces the amplitude of this cycle. The improvement by statistical post-processing is clear with almost 30% reduction of the RMSE on minimum temperatures and 20% for maximum temperature on day 1.

EMERGENCY PRODUCTIONS : Pollutant transport and dispersion forecast

For the long-range dispersion forecast, Météo-France Toulouse uses two operational tools to assess impacts in case of an accidental release:

- An air mass trajectory tool computes simple lagrangian trajectories. Three neutrally buoyant particles are released in the atmosphere at a geographic location defined by the user and at three fixed vertical levels: 950, 850 and

700 hPa, corresponding to about 500, 1500 and 3000 m above sea level in standard atmosphere. The particles are only subjected to the action of the large-scale wind; no other physical or atmospheric process is taken into account. The 3-D wind field is provided either by the global NWP models ARPEGE from Météo-France or by IFS from ECMWF (choice of the user) sampled at 0.5° resolution and on 15 vertical pressure levels, from 1000 to 100 hPa. The tool provides a quick estimate of the expected trajectory of air parcels originating from the planetary boundary layer at the location of interest.

- a dispersion model, MOCAGE-accident, based upon the MOCAGE three-dimensional chemistry and transport model developed by Météo-France for the numerical simulation of the interactions between dynamical, physical and chemical processes in the lower stratosphere and in the troposphere. MOCAGE-accident is a version of MOCAGE specifically adapted for the transport and diffusion of accidental release from the regional to the global scale. Currently, only dynamical and physical processes are taken into account, excluding chemistry.

MOCAGE-accident runs in off-line mode, using Météo-France ARPEGE or ECMWF/IFS operational NWP products as dynamical forcings.

For this long-range dispersion forecast, IFS meteorological forcing over the domain needed are extracted from Meteo-France operational Data bases, with fields disseminated to these databases from ECMWF, main fields used are the temperature, the humidity, and the wind related fields.

For local and regional scale dispersion forecast, Météo-France uses the system PERLE which is based on the combination of a mesoscale non hydrostatic model, which provides meteorological fields, and a lagrangian particle dispersion model (LPDM, from the Colorado State University), the formulation of which allows the description, during the first critical few hours, of the atmospheric pollutant cloud in the vicinity of a radionuclide or chemical release, without gaussian assumptions.

For the standard PERLE version, which is run over France in operations, the meso-scale meteorological fields considered are either AROME operational forecasts or specifically produced forecasts by the Meso-NH model (Lafore et al., 1998). In the case where Meso-NH is chosen, it uses two nested grids for emergency response, with a first domain covering 240km*240km area (4-km resolution) and a second domain covering 60km*60km area (1-km resolution), and two-way interactions between them. The initial and boundary conditions of the larger domain are provided by ARPEGE. In 2011, a “global” version of PERLE has been developed and can be used for any limited area domain over the globe, by considering IFS fields for both initial and boundary conditions of Meso-NH.

For this local and regional scale dispersion forecast, IFS meteorological forcing (temperature, humidity, and wind fields are extracted) over the domain needed .

Since July 2017, it is possible to run the PERLE model for past dates (using IFS data sets with MARS access).

CAMS

The MOCAGE chemistry transport model of Météo-France is operated daily, to provide air quality forecasts and analysis, in contribution to the CAMS¹ regional ensemble AQ² service (Marécal et al, 2015).

The two chains (analysis and forecasts) are operated independently: due to the timing constraints of ensemble forecasts delivery (before 7 UTC for the first 48h of forecasts), on one hand, and to the late availability of surface observations on the other hand, the AQ analysis results cannot provide initial values for the AQ forecasts.

Since July 2014, the forecast system has been running on the Météo-France operational supercomputer BULL system which is 24hours/day monitored. Figure 10 summarizes the forecast operational production chains. Details are given in the next paragraphs.

¹Copernicus Atmosphere Services

² AQ : Air Quality

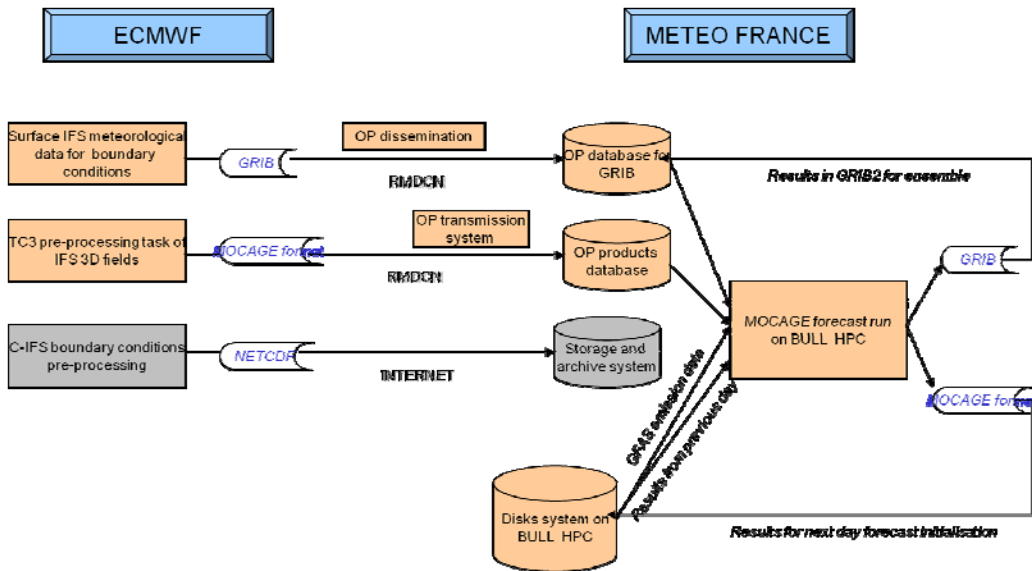

Fig. 11 : Schematic data-flow of the MOCAGE forecast chain.

The following data are used by the forecast system:

- Meteorological initial forcings

As soon as the 12 UTC IFS meteorological forecasts are produced, a time critical task is triggered at ECMWF to pre-process 3D fields data (interpolation on the CAMS domain, on MOCAGE vertical levels and conversion to suitable format for the MOCAGE model). The result files are transferred, by ECPDS, directly to Météo France's operational transmission system, and then automatically stored in an operational products database (BDPE).

Meanwhile, surface data from IFS forecasts are disseminated directly to the operational GRIB database at Météo France (BDAP).

Since the end of 2016, the 00 UTC IFS meteorological forecasts has been added to this dissemination, by using the same system. The CAMS MOCAGE analyses are now forced by this 00 UTC IFS meteorological forecasts .

- Chemical boundary conditions

Chemical boundary conditions from C-IFS are pre-processed at ECMWF into NETCDF files, and transferred to the storage and archiving system at Météo-France. The operationalization of this chain will be implemented before the end of 2017, as soon as a push option from ECMWF will be available. This will be based on a process similar to that in place for the 3D meteorological fields.

- Aerosol boundary conditions

The aerosol boundary conditions are taken from MOCAGE global model outputs which provide more detailed aerosols than the current version of the aerosol module in IFS.

- GFAS fires emission daily products

These data are retrieved from MARS, at ECMWF, and pre-processed into NETCDF files, then transferred to the storage and archiving system at Météo-France. As this chain is not yet fully operational, there is currently no plan to operationalized this chain. The MOCAGE forecasting and analyses chains can however run without these fields.

Finally, initialisation fields from the forecast of the previous day are used, directly from the HPC disk system, where they are produced.

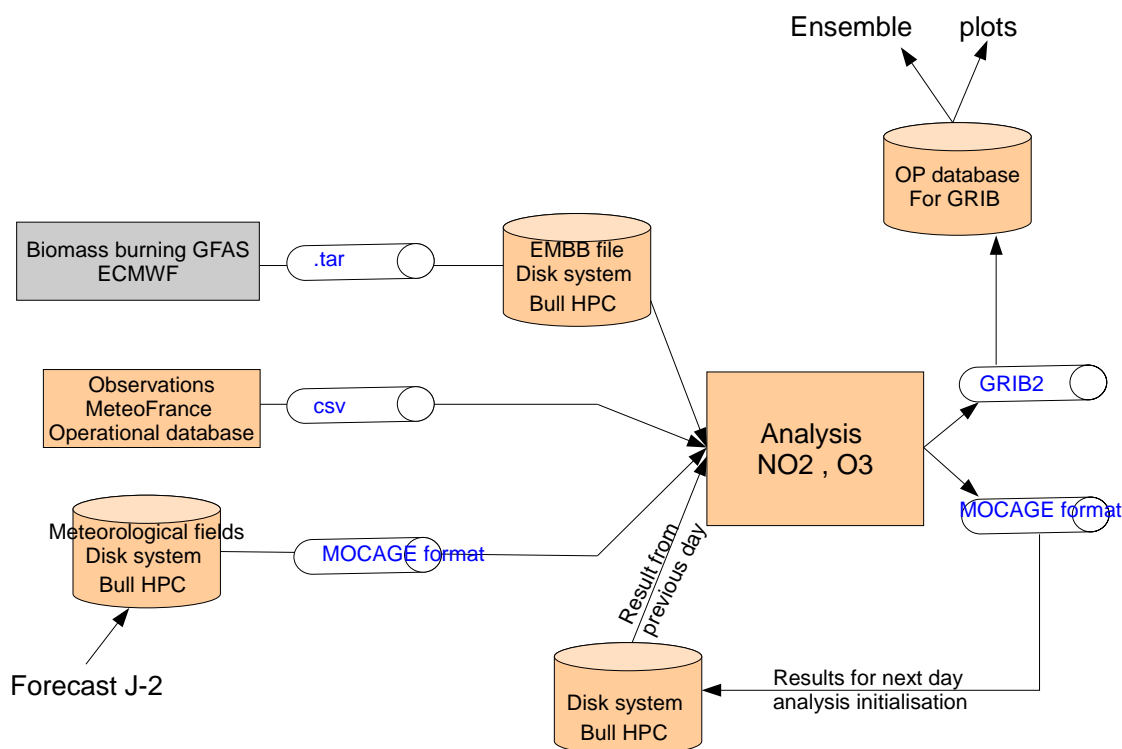

Fig 12 : Schematic data-flow of the Mocale-Valentina analysis chain. The parts in orange have an operational status, and the parts in grey are daily routine operations in a R&D environment (pre-operational).

The MOCAGE-VALENTINA analysis chain has been operational since March 2015, although some parts of it still have a pre-operational status (Figure 7). Observations are from the csv file distributed from the operational system. Meteorological forcing files are extracted from ECMWF, using the same procedure as for the Mocale forecast. GFAS products are extracted from ECMWF. Note that the MOCAGE forecast can be run, even if the GFAS and/or chemical boundary conditions are not available on time. All these data are stored in the operational data base and archiving system of Météo-France, and the analysis runs on the operational HPC at Météo-France. The grib2 files that are produced by the analysis run (resolution $0.1^\circ \times 0.1^\circ$, surface only) are stored in the Météo-France operational database, thus feeding in the operational chain for ensemble processing.

MOCAGE-VALENTINA CAMS is also operated in that context to produce interim and validated reanalyses (Reanalyses for the previous Year and for the Year-2), using the R&D HPC at Meteo-France. Boundary conditions are extracted from ECMWF using MARS system (Chemical boundary condition : depending on what has been provided by the global Copernicus system, and IFS meteorological fields).

3.1.4 End products delivered to users

3.2 Subjective verification

3.2.1 Subjective scores (including evaluation of confidence indices when available)

Monthly Forecasts of 2m temperatures have been assessed subjectively since November 2004, with a specific interest over France and nearby. The assessment is based on marks which vary from A to D with the following meaning :

A : good localisation and intensity of the anomaly,

B : slight differences (localisation and/or intensity) between observed and forecasted anomaly,

C : anomaly forecasted but not observed (conditions near normal) or (more frequently) anomaly observed but not forecasted (no signal in the forecast),

D : observed anomaly opposite to the forecasted one.

The plots below show the distribution of the marks, according to the week (time range) and the season. We consider winter season, the weeks valid during December-January-February, spring season, the weeks valid during March-April-May, and so on for summer and autumn.

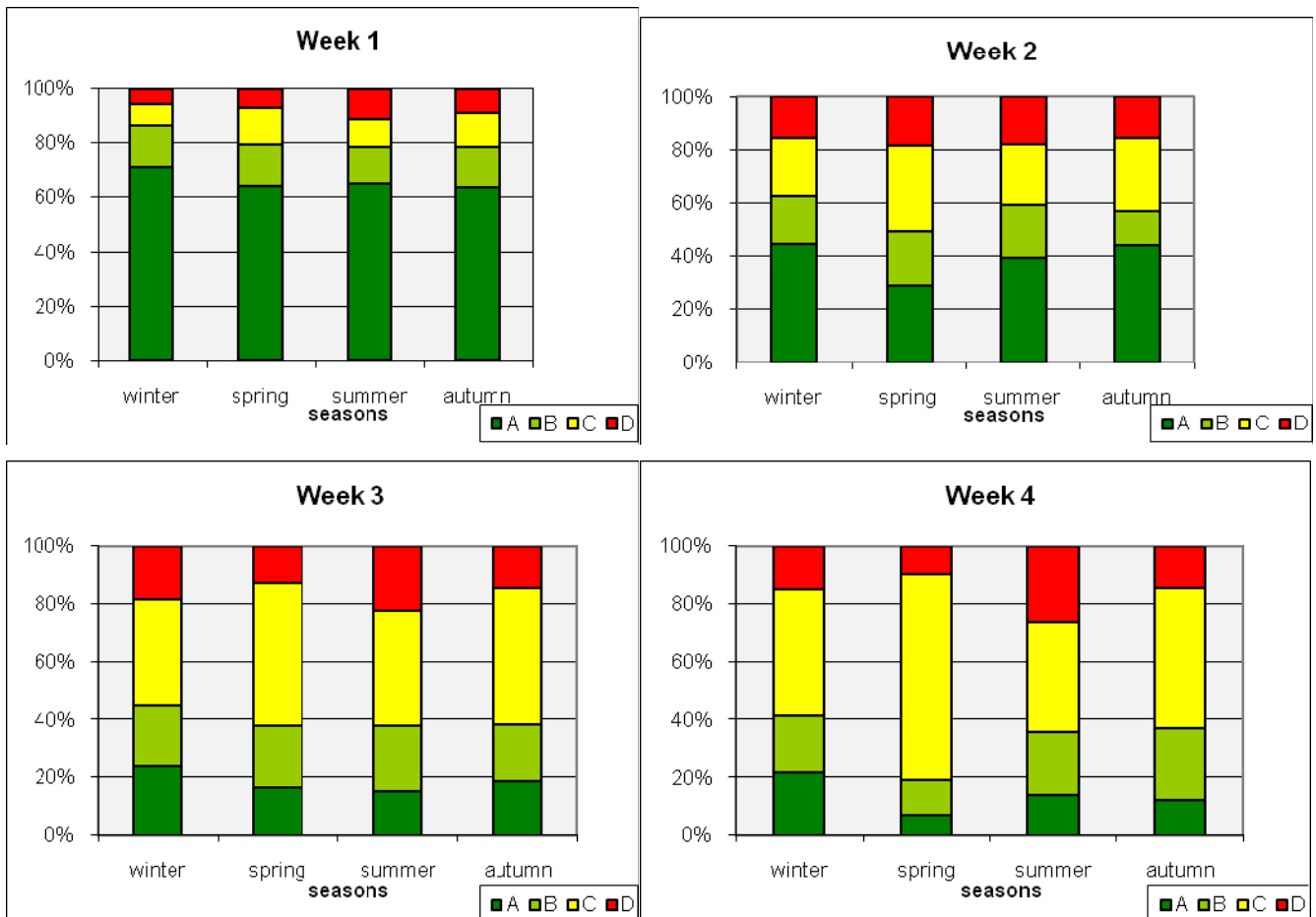

Fig. 13. Proportion of marks for 2m-temperature, according to week and season, period November 2005 – December 2016.

First remind that C marks are mainly cases when the forecast gives no signal, and the verification shows an anomaly, whereas D marks are cases when the forecasted anomaly is opposite to the observed one.

Spring and autumn are the periods when the proportion of C marks is the most frequent : we have more cases of no-signal in the forecast during the transition seasons. During winter and summer, the forecasts give signal more frequently, but not always in the right sense for week 3 and 4 : D marks are more frequent during winter and summer.

We note that winter gets the largest proportion of A+B marks (good forecasts), and spring presents the smallest proportion of these marks, specifically for week 2 and 4. Summer and autumn are quite similar, except that D marks are more frequent in summer and C in autumn (as mentioned before).

Better scores for winter may come from the effect of teleconnections (typically MJO), and from the impact of winter regimes on temperatures over Europe.

Lower scores for spring may be linked with spring predictability limit well known in seasonal forecast.

Finally, we want to stress that, for winter, the scores are very similar between week 3 and 4. So we can speculate that there is probably some skill for week 5 and 6, at least in winter.

3.2.2 Case studies

4. Feedback on ECMWF “forecast user” initiatives

5. References to relevant publications

Marécal, V. et al., 2015: A regional air quality forecasting system over Europe: the MACC-II daily ensemble production, *Geosci. Model Dev.*, **8**, 2777-2813, doi:10.5194/gmd-8-2777-2015, 2015.

Zamo, M., 2016: Statistical Post-processing of Deterministic and Ensemble Wind Speed Forecasts on a Grid, *Paris-Saclay University Phd thesis NNT : 2016SACLA029*